

Type DFD

Vertical version

Three-phase filter reactor to EN 61558-2-20 / VDE 0570-2-20

Application

Use in reactive current compensation systems for defined elimination of harmonics. Connected in series with capacitors, the reactor can be matched optimally to the conditions of the system, depending on the dominating harmonics. The impedance characteristics of the system improve. Filter reactors prevent loss due to capacitor overload.

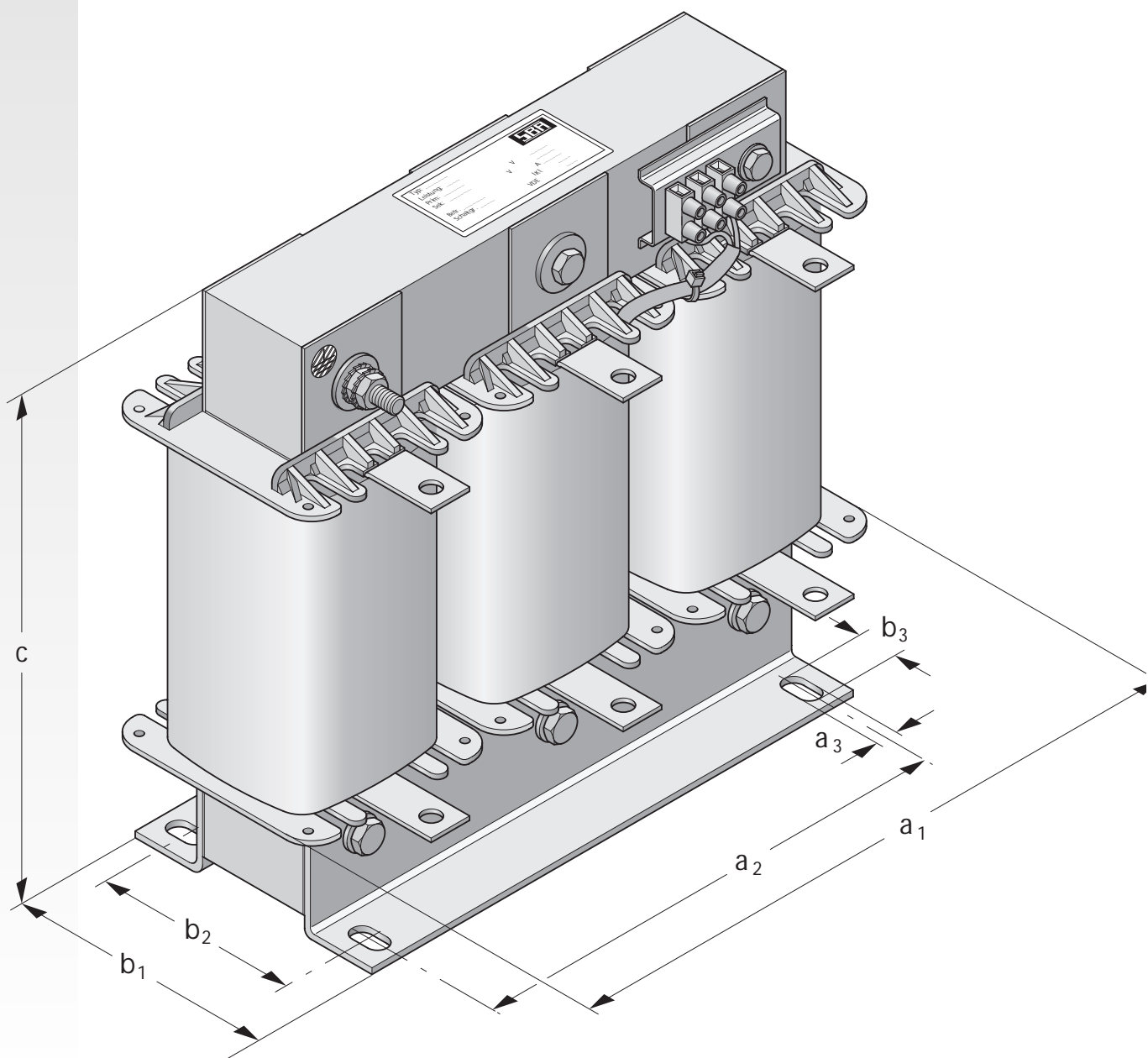

TYPE DFD

THREE-PHASE FILTER REACTORS



Construction

- ➔ Open construction (IP 00, incorporation up to max. IP 23)
- ➔ Resting on angular feet (DIN 41307)
- ➔ Depending on rated current: screw terminals or flat termination with bolt
- ➔ Integrated thermal switch (breaking at 250 V/2.5 A)
- ➔ Very low-noise due to special core assembly and high-grade vacuum impregnation in black polyester impregnating resin
- ➔ Wear-resistant, heat, UV and solvent resistant nameplate
- ➔ **Special versions** available on request

Specifications

System compensation	up to	75 kVAr
Inductance balancing	± 3 % rel. to	I_{Nom}
Supply voltage		3 x 400 V
Frequency		50 Hz
Protection class		I
Protection index		IP 00
Insulation class		B/F
Ambient temperature		max. 40° C, max. 50° C, resp.

Overview

more data, see pages 36 - 37

Size	Weight kg	a_1	b_1	a_2	Dimensions b_2 approx. mm	a_3	b_3	c
208	4.2	120	92	81	57	6	8	112
209	5.0	150	81	106	61	7	13	142
210	6.0	150	96	106	76	7	13	142
211	7.5	180	86	106	66	7	13	162
212	12.0	180	106	106	86	7	13	162
215	16.0	228	90	176	71	7	13	205
216	20.0	228	114	176	95	7	13	205
221	23.0	264	106	200	76	10	18	235
222	26.0	264	132	200	102	10	18	235
223	33.0	300	122	224	94	10	18	270
224	48.0	300	147	224	119	10	18	270
228	62.0	360	168	264	140	10	18	320

Copyright © 2002-2005 SBA

SBA-TrafoTech GmbH
Winkelleite 14
91332 Heiligenstadt, Germany
Telephone +49 (0)9198/8 09-19
Facsimile +49 (0)9198/8 09-30
sales@sba.de

SBA-Trafobau Jena GmbH
Ilmstraße 18
07743 Jena, Germany
Telephone +49 (0)3641/4514-0
Facsimile +49 (0)3641/4514-30
info@sba.de

Internet: www.sba.de

Type DFD

Horizontal version

Three-phase filter reactor to EN 61558-2-20 / VDE 0570-2-20

Application

Use in reactive current compensation systems for defined elimination of harmonics. Connected in series with capacitors, the reactor can be matched optimally to the conditions of the system, depending on the dominating harmonics. The impedance characteristics of the system improve. Filter reactors prevent loss due to capacitor overload.

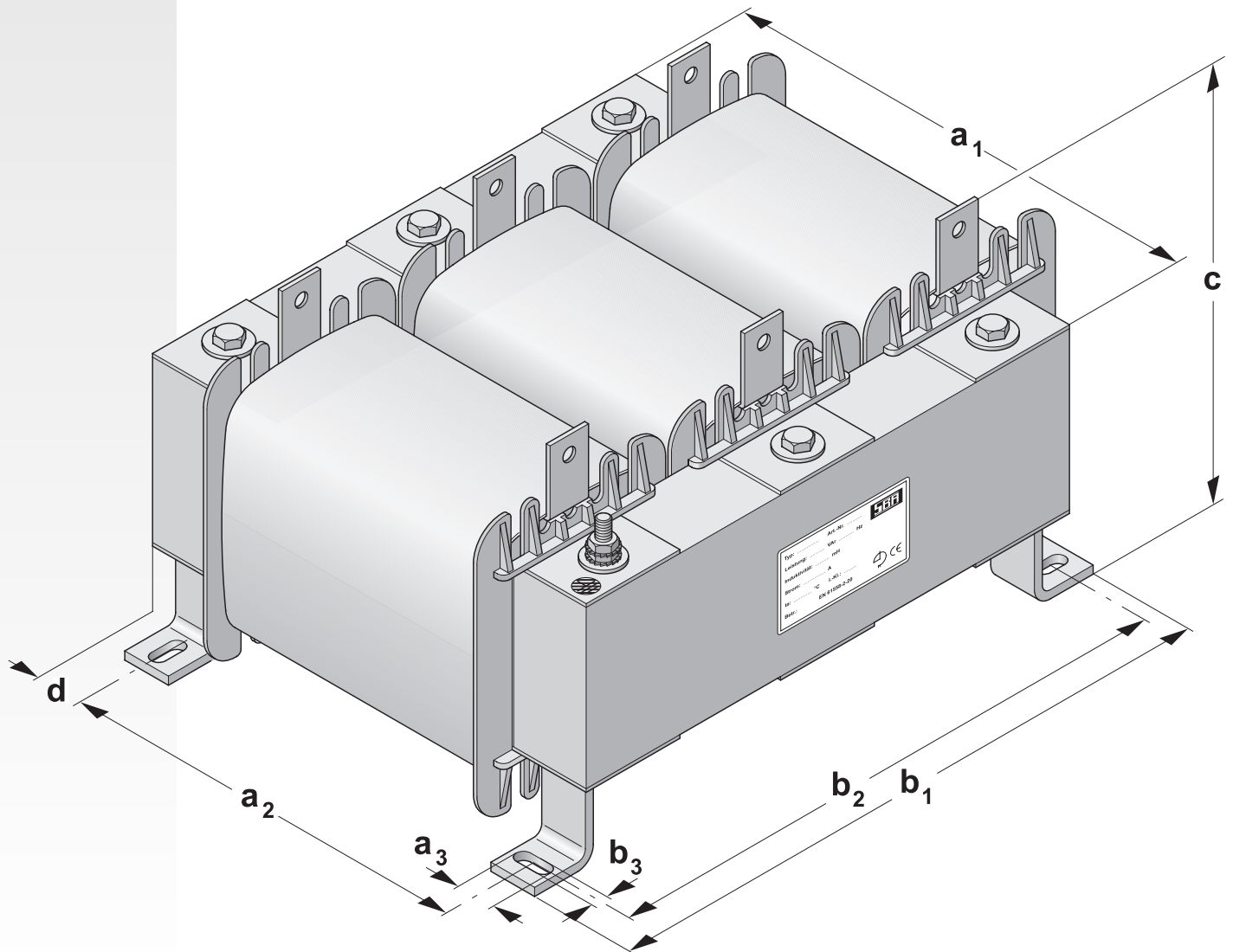

Copyright © 2002-2005 SBA

TYPE DFD

THREE-PHASE FILTER REACTORS



Construction

- ➔ Open construction (IP 00, incorporation up to max. IP 23)
- ➔ Resting on angular feet (DIN 41307)
- ➔ Depending on rated current: screw terminals or flat termination with bolt
- ➔ Integrated thermal switch (breaking at 250 V/2.5 A)
- ➔ Very low-noise due to special core assembly and high-grade vacuum impregnation in black polyester impregnating resin
- ➔ Wear-resistant, heat, UV and solvent resistant nameplate
- ➔ **Special versions** available on request

Specifications

System compensation	up to	75 kVAr
Inductance balancing	± 3 % zu	I_{nom}
Supply voltage		3 x 400 V
Frequency		50 Hz
Protection class		I
Protection index		IP 00
Insulation class		B/F
Ambient temperature		max. 40° C bzw. max. 50° C

Overview

more data, see pages 36 - 37

Size	Weight kg	a ₁	b ₁	a ₂	Dimensions b ₂ approx.mm	a ₃	b ₃	c
208*	4.2	165	120	83	133	8	6	88
209*	5.0	170	185	103	165	10	7	85
210*	6.0	170	185	103	165	10	7	115
211*	7.5	195	206	125	184	10	7	110
212*	12.0	195	206	125	184	10	7	130
215*	16.0	240	254	157	228	10	7	124
216**	20.0	200	254	157	228	10	7	143
221**	23.0	230	290	181	258	14	9	131
222**	26.0	230	290	181	258	14	9	157
223**	33.0	260	330	205	298	14	9	143
224**	48.0	260	330	205	298	14	9	168
228**	62.0	310	394	245	358	14	9	214

* Connection to terminals

** Connection to flat termination with bolt

Copyright © 2002-2005 SBA

SBA-TrafoTech GmbH

Winkelleite 14
91332 Heiligenstadt, Germany
Telephone +49 (0)9198/8 09-19
Facsimile +49 (0)9198/8 09-30
sales@sba.de

SBA-Trafobau Jena GmbH

Ilmstraße 18
07743 Jena, Germany
Telephone +49 (0)3641/4514-0
Facsimile +49 (0)3641/4514-30
info@sba.de

Internet: www.sba.de

Type DFD

Three-phase filter reactor to EN 61558-2-20 / VDE 0570-2-20

Thermal Design:

$$1,05 \times I_{eff} \text{ where } I_{eff} = \sqrt{I_1^2 + I_3^2 + I_5^2 + I_7^2}$$

Magnetic linearity:

$$1,05 \times (I_1 + I_3 + I_5 + I_7) \text{ where } L > 0,95L_{nom}$$

Fundamental component:

1.06 times the rated current of the 1st fundamental

Harmonic component:

3rd harmonic 150 Hz at 0.5%

5th harmonic 250 Hz at 5.0%

7th harmonic 350 Hz at 5.0%

Overview

Reactor factor: 5.67%

Size	Reactive power kVAr	Inductance (phase) mH	Capacitance (star) µF	Current A	Thermal current A	Total loss W	Insu- lation- class
208	2.5	12.3	46.9	3.82	4.6	35	T40/B
210	5	6.13	93.9	7.65	9.2	40	T40/B
212	10	3.06	187.8	15.30	18.4	68	T40/B
215	12.5	2.45	234.7	19.10	23.0	80	T40/B
215	15	2.04	281.6	23.00	27.6	100	T40/B
216	20	1.53	375.5	30.60	36.8	101	T40/B
216*	25	1.23	469.4	38.30	46.0	114	T40/B
221*	30	1.02	563.3	45.90	55.2	142	T40/B
222*	40	0.77	751.0	61.20	73.6	162	T40/B
224*	50	0.61	938.8	76.50	92.0	200	T40/B
224*	75	0.41	1408.0	114.80	138.0	250	T40/B

*Connection to flat termination with bolt

TYPE DFD

THREE-PHASE FILTER REACTORS



Overview

Reactor factor: 7%

Size vertical version	Size horizontal version	Reactive power kVAr	Inductance (phase) mH	Capacitance (star) µF	Current A	Thermal current A	Total loss W	Insu- lation class
208-5024	208-5006	2.5	15.30	46.3	3.82	4.2	32	T50/B
209-5008	209-5010	5	7.67	92.6	7.65	8.4	49	T50/B
211-5012	211-5030	10	3.84	185.1	15.30	16.9	65	T50/B
212-5018	212-5028	12.5	3.07	231.4	19.10	21.1	69	T50/B
215-5018	215-5068	15	2.56	277.7	23.00	25.3	76	T50/B
215-5016	215-5076	20	1.92	370.2	30.60	33.7	100	T50/B
216-5015*	216-5025	25	1.53	462.8	38.30	42.2	130	T50/B
216-5046*	216-5031	30	1.28	555.3	45.90	50.6	116	T50/B
221-5009*	221-5019	40	0.96	740.4	61.20	67.5	138	T50/B
223-5009*	223-5010	50	0.77	925.6	76.50	84.3	160	T50/B
224-5124	224-5119	75	0.51	1389.0	114.80	127.0	230	T40/B

*Connection to flat termination with bolt

Overview

Reactor factor: 14%

Size	Reactive power kVAr	Inductance (phase) mH	Capacitance (star) µF	Current A	Thermal current A	Total loss W	Insu- lation- class
209	2.5	33.20	42.8	3.82	4.0	45	T40/B
212	5	16.60	85.6	7.65	8.1	53	T40/B
215	10	8.30	171.2	15.30	16.2	78	T40/B
215	12.5	6.64	214.0	19.10	20.2	93	T40/B
216	15	5.53	256.8	23.00	24.3	89	T40/B
216*	20	4.15	342.4	30.60	32.3	118	T40/B
221*	25	3.32	427.9	38.30	40.4	120	T40/B
222*	30	2.77	513.5	45.90	48.5	140	T40/B
224*	40	2.07	684.7	61.20	64.6	181	T40/B
224*	50	1.66	855.9	76.50	80.8	190	T40/B
228*	75	1.11	1284.0	114.80	121.0	412	T40/B

*Connection to flat termination with bolt

Copyright © 2002-2005 SBA

SBA-TrafoTech GmbH
Winkelleite 14
91332 Heiligenstadt, Germany
Telephone +49 (0)9198/8 09-19
Facsimile +49 (0)9198/8 09-30
sales@sba.de

SBA-Trafobau Jena GmbH
Ilmstraße 18
07743 Jena, Germany
Telephone +49 (0)3641/4514-0
Facsimile +49 (0)3641/4514-30
info@sba.de

Internet: www.sba.de